

PROFILE SYSTEM: FORSTER THERM TÜR, DEPTH 70MM  
 MATERIAL QUALITY: PROFILES IN STEEL  
 LOCK VERSION 1: FORSTER MORTISE LOCK WITHOUT TOP SHOOT BOLT (LOCKING FUNCTIONS W, L+W, D, B)  
 LOCK VERSION 2: FORSTER MORTISE LOCK WITH TOP SHOOT BOLT (LOCKING FUNCTIONS L+W, D, B)  
 LOCK VERSION 3: MULTI-POINT LOCK RESISTANCE CLASS (RC) 1-3  
 IRONMONGERY: FORSTER STAINLESS STEEL HANDLE (BOTH SIDES) OR FORSTER STAINLESS STEEL KNOB WITH STAINLESS STEEL HANDLE INC. ROSETTE  
 HINGES: 2 OR 3 HINGES PER LEAF  
 ADJUSTABLE (HIGHT) FORSTER WELO-ON HINGE OR ADJUSTABLE (3DIM.) FORSTER WELO-ON  
 DOOR CLOSER: ATTACHED DOOR CLOSER, E.G. TYPE DORMA  
 PREPARED PROFILES: LOCK INSTALLATION  
 FILLINGS: INSULATED GLASS E.G. 28MM  
 WET GLAZING WITH CERAMIC STRIPS AND SILICONE OR DRY GLAZING WITH GASKET  
 TREATMENT STEEL: FORSTER PROFILES GALVANIZED AND ANOYELLOW CHROMATED, ELEMENT BOTH SIDES CLEANED AND COATED ON SITE, ELEMENT PREVIOUSLY SAND BLASTED, ZINC COATED AND POWDER COATED

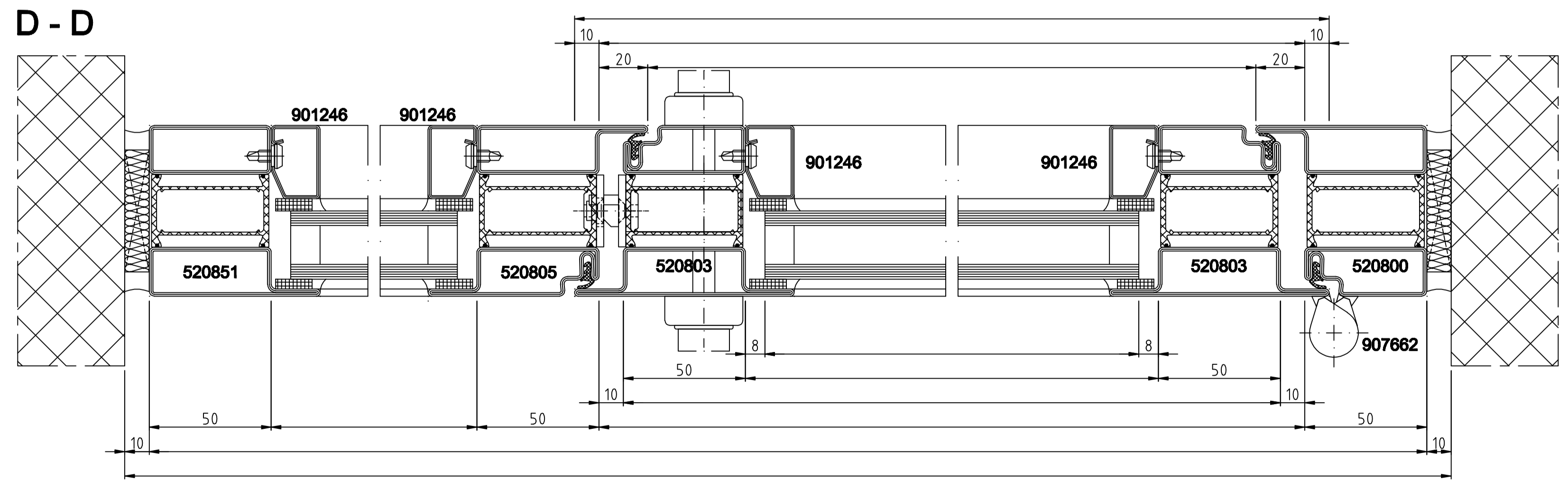
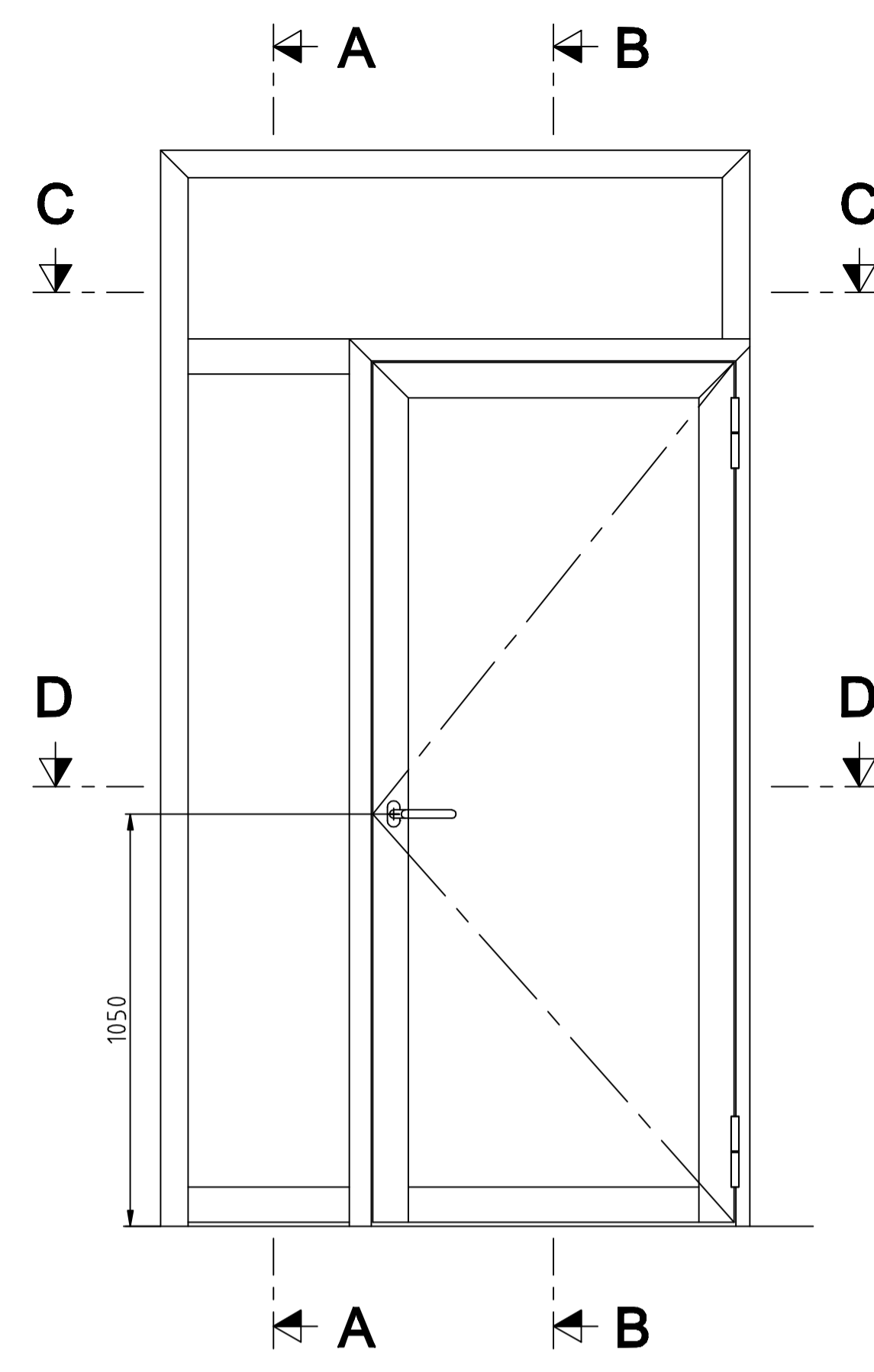

The copyright in all of our drawings remains with our company. They may not be copied, nor made accessible to third parties without our express written permission. All drawings and possible static calculations must be checked. No legal claims are possible from their use.

Weight		Replacement for	
Drawn	24.01.05	By	
forster Therm Tür	1:1	Examined	
1-leaf door with fanlight and sidelight	1:10	Status	
Type 04			

**forster** Forster Bau- & Profitechnik AG  
 Forster Profile Systeme  
 04-3122 Altona